

TriStar® Pump - SP3200 Series

SELF-PRIMING SWIMMING POOL PUMP

INSTALLATION AND OPERATING INSTRUCTION MANUAL

Your Hayward TriStar Pump has been specifically engineered for the demanding requirements of today's in-ground swimming pool or spa. The TriStar is a self-priming pump that includes an improved seal and impeller design that will provide many years of efficient, dependable, corrosion-free service. The advanced design provides superior performance and efficiency requiring the plumbing to be 50mm or larger with the suction line no smaller in diameter than the discharge line.

IMPORTANT

*This appliance is not intended for use by young children or infirm persons unless they have been adequately supervised by a responsible person to ensure they can use the appliance safely.

*Young children should be supervised to ensure that they do not play with the appliance.

GENERAL TIPS ON PUMP INSTALLATION

Locate the pump as close to pool as practical and run suction line as direct as possible. Secure pump to base with screws or bolts to reduce vibration and pipe stress.

Never overtighten pipe connections—use only pipe sealants formulated specifically for plastics, i.e., Teflon tape, Permatex No. 2, etc.

Suction line should have continuous slope from lowest point in line. Make sure suction joints are tight. Suction pipe should be as large or larger than discharge pipe.

Damp, non-ventilated locations should be avoided. Motors require free circulation of air to aid in cooling.

Ensure that the electrical supply available agrees with motor's voltage and is 50 HZ, and that wire size is adequate for the KW rating and distance from power source. Motor must always be properly earthed. Electrical circuits must be supplied through a Residual Current Device - RCD (safety switch), with a rated residual operating current of 30mA. All electrical wiring must be performed by qualified electrical contractor, and must conform to electrical regulations and AS3000 wiring rules.

STARTING AND PRIMING INSTRUCTIONS

Fill strainer/housing with water to suction pipe level. Never operate the pump without water. Water acts as a coolant and lubricant for the mechanical shaft seal.

Open all suction and discharge lines and valves, as well as air bleed (if available) on filter. (The air that is to be displaced from the suction line must have some place to go.)

CAUTION: All suction and discharge valves must be open when starting the system. Failure to do so could cause severe personal injury and/or property damage.

Turn on power and allow a reasonable time for priming. Five minutes is not unreasonable. (Priming time depends on suction lift and horizontal length of suction piping.) If the pump will not start, or will not prime, see TROUBLE SHOOTING GUIDE on back page.

Notice for Solar Applications

A check valve must be fitted to the discharge of the pump when installed with solar system.

Special Notice for 415V. 3 Phase Models

Only a qualified electrician may connect or disconnect this pump to/from a power supply.

The motor must be connected by means of fixed wiring so that the IP rating is maintained when doing so. Electrician must check direction of rotation at time of installation.

The motor is not suitable for flex and plug connection as starter/contactors with overload is required and this must be set according to the rated current.



Parts Diagram

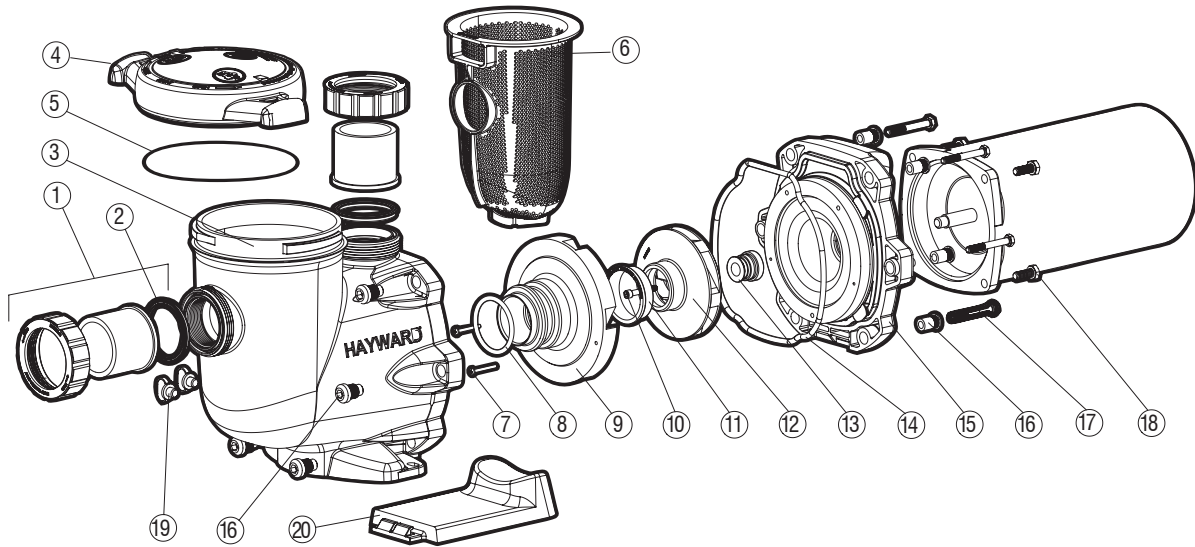

Parts Listing

Ref. No.	Part No.	Description	Qty. Req'd
1	SPX3200UNKIT	Union Connector Kit (Includes Union Nut, Connector, Gasket - 2 ea.)	1
2	SPX3200UG	Union Gasket	2
3	SPX3200A	Pump Strainer Housing, 2" x 2½" with Drain Plugs, threaded style	1
4	SPX3200DLS	Strainer Cover Kit (Includes Strainer Cover, Lock Ring, O-Ring)	1
5	SPX3200S	Strainer Cover O-Ring	1
6	SPX3200M	Strainer Basket	1
7	SPX3200Z8	Diffuser Screw	2
8	SPX4000Z1	Diffuser O-Ring	1
9	SPX3200B3	Diffuser	1
10	SPX3200Z1	Impeller Screw	1
11	SPX3021R	Impeller Ring	1
12	SPX3210C	Impeller (suit SP3210AQ 1 H.P)	1
	SPX3215C	Impeller (suit SP3215AQ 1½ H.P)	1
	SPX3230C	Impeller (suit SP32302AQ 2 H.P)	1
	SPX3230CU	Impeller (suit SP3230UAQ 3 H.P)	1
13	SPX4000SA	Shaft Seal Assembly	1
14	SPX3200T	Housing O-Ring	1
15	SPX3200E	Seal Plate	1
16	SPX3200Z211	Housing Insert/Seal Plate Spacer Kit	6
17	SPX3200Z3	Housing Bolt	6
18	SPX3200Z5	Motor Bolt	4
19	SPX4000FG	Drain Plug with O-Ring	2
20	SPX3200GA	Bracket, Motor Support TriStar	1
--	SPX3210AQM	Motor (suit SP3210AQ 1 H.P)	1
--	SPX3215AQM	Motor (suit SP3215AQ 1½ H.P)	1
--	SPX32302AQM	Motor (suit SP32302AQ 2 H.P)	1
--	SPX3230UAQM	Motor (suit SP3230UAQ 3 H.P)	1
--	SPX3200Q	Adaptor - Motor Support - use on SPX3200GA in Australia - Not Shown	1

USE ONLY HAYWARD GENUINE REPLACEMENT PARTS

TriStar Pump

Shaft Seal Change Instructions

IMPORTANT SAFETY INSTRUCTIONS **PLEASE READ AND FOLLOW ALL INSTRUCTIONS**

When servicing electrical equipment, basic safety precautions should always be observed including the following. Failure to follow the instructions may result in injury.

- Disconnect the pump motor power cord from the power outlet before beginning the shaft seal replacement.
- Only qualified personnel should attempt to replace the shaft seal. Contact your local authorized Hayward Dealer or service center if you have any questions.
- Exercise extreme care in handling both the rotating and stationary sections of the two-part replacement seal. Foreign matter or improper handling will easily scratch the graphite and ceramic sealing surfaces.
- See the "Parts Diagram" on the previous page for the pump component locations.

Removing the Motor Assembly

1. Remove the six (6) 5/16" x 2" hex head bolts (Item 17), which hold the motor assembly to the pump/strainer housing (item 3), using a 1/2" AF spanner or socket.
2. Slide the motor assembly out of the pump/strainer housing (item 3), exposing the diffuser (item 9). Remove the two (2) diffuser screws (item 7), and pull the diffuser (item 9) off the seal plate (item 15) to expose the impeller (item 12).

Removing the Impeller

1. To prevent the motor shaft from turning, insert a Flat Blade Screwdriver through the center hole in the fan cowling and into the slot on the end of the motor shaft and hold it.
2. Rotate the impeller screw (item 10) clockwise (**NOTE: this screw has a left-hand thread**) and remove. Remove the impeller (item 12) by rotating it counterclockwise.

Removing the Ceramic Seat

1. Remove the spring seal assembly (item 13) and seal plate (item 15) from the motor by removing the four (4) 3/8" x 1" bolts (item 18) that secure it to the motor, using a 9/16" AF spanner or socket. Remove the motor support bracket (item 20) from the seal plate (item 15).
2. Press the ceramic seat with rubber cup out of the seal plate (item 15). If tight, use a small screwdriver to tap the seal out from the back side of the seal plate.

! **IMPORTANT** - Clean all recesses and parts to be reassembled. Inspect gaskets and replace if necessary.

Seal, Impeller, and Diffuser Installation

1. Clean and lightly lubricate the motor shaft and seal recess in the seal plate (item 15) with a dilute solution of non granulated liquid type soap. Gently wipe the polished face of the ceramic seal with a soft, lint free cotten cloth. Lubricate the rubber cup on the ceramic seat and press it firmly into the recess of the seal plate (item 15), with the polished ceramic surface facing towards you.
2. Reassemble the motor to the seal plate (item 15) using the four (4) 3/8" x 1" bolts (item 18) by tightening them in a cross pattern. Ensure there is equal clearance between the motor shaft and ceramic seat. Re-attach the motor support (item 20) to the seal plate (item 15).
3. Gently wipe the black, polished surface of the carbon spring seal assembly (item 13) with a soft, lint free cotton cloth.
4. Press the carbon spring seal assembly (item 13) onto the motor shaft, with the black polished surface facing the ceramic seat.
5. Screw the impeller (item 12) onto the motor shaft in a clockwise direction and tightn snugly by holding the motor shaft with the Flat Blade Screwdriver as explained earlier. Screw the impeller screw (item 10) into the motor shaft in a counterclockwise direction. Place the impeller ring (item 11) back onto the impeller (item 12), with its flange facing towards the diffuser (item 9).
6. Place the diffuser (item 9) over the impeller (item 12) and onto the seal plate (item 15), aligning the three (3) pins on the diffuser (item 9) with the three (3) holes on the seal plate (item 15). Replace the two (2) diffuser screws (item 7).
7. Replace the motor Assembly into the pump/strainer housing in the reverse order of the removal steps. Ensure the housing gasket (item 14) is lubricated and tighten the housing bolts (item 17) in a cross pattern evenly and to a torque of 21 Newton Meters.

USE ONLY HAYWARD GENUINE REPLACEMENT PARTS

TriStar Pump

MAXIMUM TOTAL HEAD - IMPORTANT INSTALLATION INFORMATION

Model	Max Total Metres Head	Max Pressure kPa	Model	Max Total Metres Head	Max Pressure kPa
SP3210AQ / TS350	17.7	174	SP32302AQ / TS525	20.8	204
SP3215AQ / TS425	19.3	189	SP3230UAQ / TS600	24.9	244

MAINTENANCE

1. Clean strainer basket regularly. Do not strike basket to clean.
2. Inspect strainer cover O-ring regularly and replace as necessary. Keep cover O-ring lubricated.
3. Hayward pumps have self-lubricating motor bearings and shaft seals. No lubrication is necessary.
4. Keep motor clean. Insure air vents are free from obstruction.

NB Do not use petroleum based lubricants on gaskets, O-rings or plastic components.

Use only silicone based lubricants.

A. MOTOR WON'T START

1. Check open switches or relays, blown circuit breakers or fuses.
2. Ensure power cord is plugged in and power is switched on, (240v Models Only).
3. Refer to Authorised Service Agent or other qualified person.

B MOTOR CUTS OUT

NOTE: Your Hayward pump motor is equipped with Automatic Thermal Overload Protection. The motor will automatically shut-off, under normal conditions, before heat damage buildup, due to an improper operating condition, can occur. The motor will auto-restart when safe heat level is reached.

If motor fails to restart switch power off and contact an authorised Hayward Pump Service Technician or other qualified service company.

C. MOTOR HUMS, BUT DOES NOT START

If motor fails to start switch power off and contact an authorised Hayward Pump Service Technician or other qualified service company.

D. PUMP WON'T PRIME

1. Make sure pump/strainer is filled with water, and that cover gasket is clean and properly seated. Tighten the strainer cover lock ring by hand only.

2. Make sure all suction and discharge valves are open and unobstructed, and that pool water level is above all suction openings.

E. LOW FLOW—Generally, check for:

1. Clogged or restricted strainer or suction line;
2. Plugged or restricted discharge line of filter (high discharge gauge reading).
3. Air leak in suction (bubbles issuing from return fittings).

F. NOISY PUMP—Check for:

1. Air leak in suction causing rumbling in pump.
2. Cavitation due to restricted or undersized suction line and restricted discharge lines.
3. Vibration due to improper mounting, etc.
4. Foreign matter in pump housing.
5. Motor bearings made unserviceable by wear, rust, or continual overheating. Refer to authorised service agent.

G. If the Supply Cord is damaged, it must be replaced by the manufacture, its service agent or similarly qualified persons in order to avoid a hazard.

SERVICE & REPAIRS

Consult your local authorised Hayward dealer or service center. No pumps or motors may be returned directly to the factory without the expressed written authorisation of Hayward Pool Products (Australia) Pty Ltd.

Warning

The Pump Motor is an electrical device and as such should not be disassembled or serviced by anyone other than an authorised Hayward Service Technician or qualified Electrical Service Company. An experienced Pool Service Technician should attend to any other problems that cannot be corrected by routine maintenance.



Hayward Pool Products (Australia) Pty Ltd.

Melbourne-Sydney-Brisbane-Perth

Email: sales@hayward-pool.com.au Website: www.hayward-pool.com.au

HEAD OFFICE: 163-165 Greens Road, Dandenong South, Vic. 3175

P.O. Box 4384, Dandenong South, Vic. 3164

ABN 66 083 413 414

Sales Ph 1300POOLS1, Fx 1300 POOLS2

